

# AP15P03Q

## P-Channel Enhancement Mosfet

### Feature

- -30V,-12A  
 $R_{DS(ON)} < 18m\Omega @ V_{GS} = -10V$  TYP:15 m $\Omega$   
 $R_{DS(ON)} < 35m\Omega @ V_{GS} = -4.5V$  TYP:25 m $\Omega$
- Trench DMOS Power MOSFET
- Fast Switching
- Exceptional on-resistance and maximum DC current capability

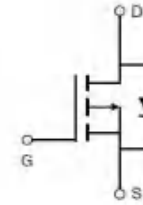

Schematic Diagram

### Application

- DC/DC Converter
- Load Switch for Portable Devices
- Battery Switch



Marking and pin Assignment

### Package Marking and Ordering Information

Device Marking	Device	Device Package	Reel Size	Tape width	Quantity (PCS)
15P03Q	AP15P03Q	PDFN3X3	13 inch	-	5000

### ABSOLUTE MAXIMUM RATINGS ( $T_a=25^\circ\text{C}$ unless otherwise noted)

Parameter	Symbol	Value	Unit
Drain-Source Voltage	$V_{DS}$	-30	V
Gate-Source Voltage	$V_{GS}$	$\pm 20$	V
Continuous Drain Current ( $T_c=25^\circ\text{C}$ )	$I_D$	-12	A
Continuous Drain Current ( $T_c=100^\circ\text{C}$ )	$I_D$	-7.8	A
Pulsed Drain Current <sup>(1)</sup>	$I_{DM}$	-48	A
Single Pulsed Avalanche Energy <sup>(4)</sup>	$E_{AS}$	25	mJ
Power Dissipation	$P_D$	4.8	W
Thermal Resistance from Junction to Ambient	$R_{\theta JA}$	26	$^\circ\text{C}/\text{W}$
Junction Temperature	$T_J$	150	$^\circ\text{C}$
Storage Temperature	$T_{STG}$	-55~ +150	$^\circ\text{C}$

# AP15P03Q

## P-Channel Enhancement Mosfet

### MOSFET ELECTRICAL CHARACTERISTICS( $T_a=25^\circ\text{C}$ unless otherwise noted)

Parameter	Symbol	Test Condition	Min	Type	Max	Unit
<b>Static Characteristics</b>						
Drain-source breakdown voltage	$V_{(BR)DSS}$	$V_{GS} = 0V, I_D = -250\mu A$	-30	-	-	V
Zero gate voltage drain current	$I_{DSS}$	$V_{DS} = -30V, V_{GS} = 0V$	-	-	-1	$\mu A$
Gate-body leakage current	$I_{GSS}$	$V_{GS} = \pm 20V, V_{DS} = 0V$	-	-	$\pm 100$	nA
Gate threshold voltage <sup>(2)</sup>	$V_{GS(th)}$	$V_{DS} = V_{GS}, I_D = -250\mu A$	-1	-1.5	-2.5	V
Drain-source on-resistance <sup>(2)</sup>	$R_{DS(on)}$	$V_{GS} = -10V, I_D = -10A$	-	15	18	m $\Omega$
		$V_{GS} = -4.5V, I_D = -10A$	-	25	34	
<b>Dynamic characteristics</b>						
Input Capacitance	$C_{iss}$	$V_{DS} = -15V, V_{GS} = 0V, f = 1MHz$	-	1550	-	pF
Output Capacitance	$C_{oss}$		-	327	-	
Reverse Transfer Capacitance	$C_{rss}$		-	278	-	
<b>Switching characteristics</b>						
Turn-on delay time	$t_{d(on)}$	$V_{DD} = -15V, I_D = 6A$ $V_{GS} = -10V, R_G = 2.5\Omega$	-	14	-	ns
Turn-on rise time	$t_r$		-	20	-	
Turn-off delay time	$t_{d(off)}$		-	95	-	
Turn-off fall time	$t_f$		-	65	-	
Total Gate Charge	$Q_g$	$V_{DS} = -15V, I_D = -10A,$ $V_{GS} = -10V$	-	30	-	nC
Gate-Source Charge	$Q_{gs}$		-	5.3	-	
Gate-Drain Charge	$Q_{gd}$		-	7.6	-	
<b>Source-Drain Diode characteristics</b>						
Diode Forward voltage <sup>(2)</sup>	$V_{DS}$	$V_{GS} = 0V, I_S = -10A$	-	-	-1.2	V
Diode Forward current <sup>(3)</sup>	$I_S$		-	-	-10	A

#### Notes:

1. Repetitive Rating: pulse width limited by maximum junction temperature
2. Pulse Test: pulse width  $\leq 300\mu s$ , duty cycle  $\leq 2\%$
3. Surface Mounted on FR4 Board,  $t \leq 10$  sec
4.  $L = 0.5mH, V_{DD} = -15V, R_G = 25\Omega, T_J = 25^\circ C$

Gate Charge Test Circuit & Waveform

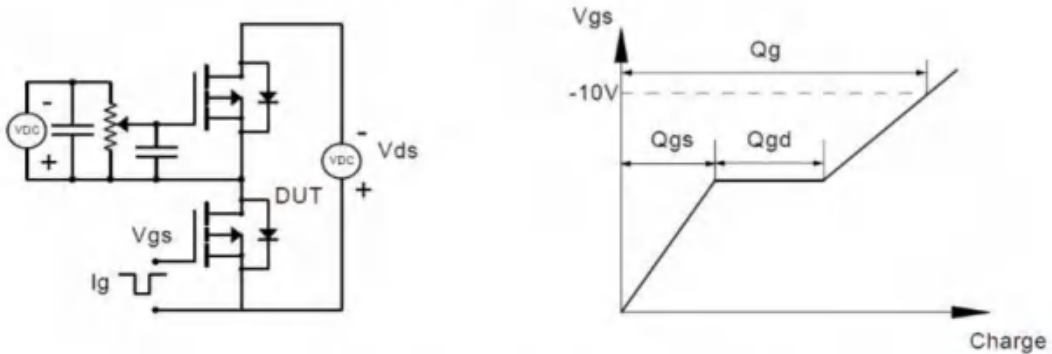

Resistive Switching Test Circuit & Waveforms

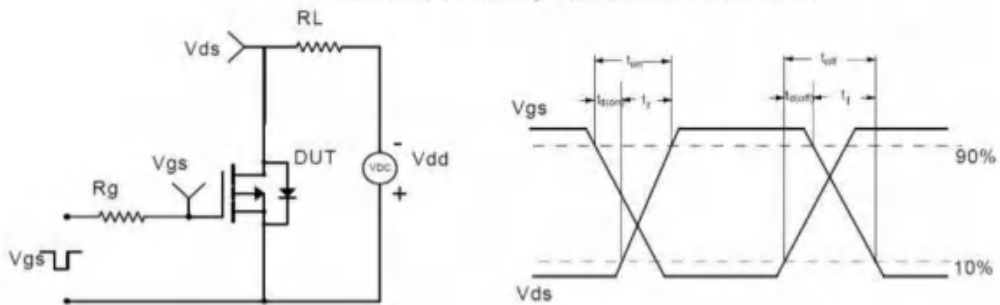

Unclamped Inductive Switching (UIS) Test Circuit & Waveforms

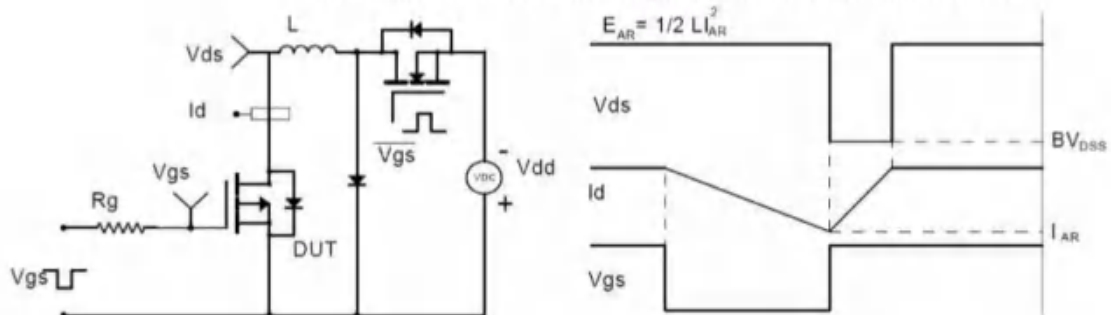

Diode Recovery Test Circuit & Waveforms

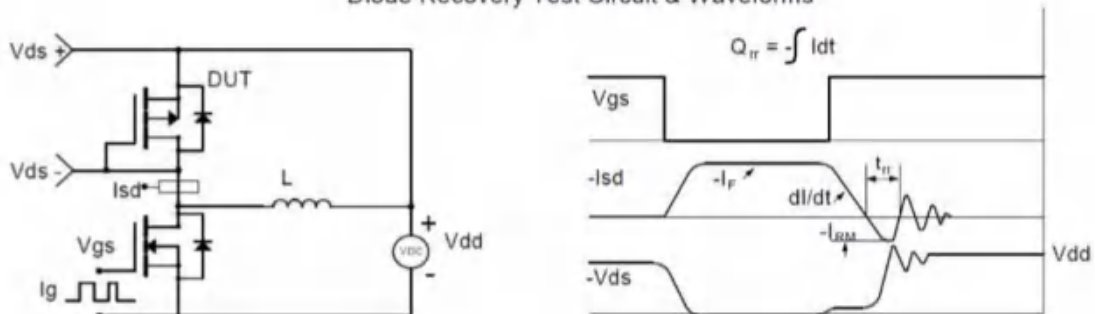

**Typical Performance Characteristics**

**Figure 1: Output Characteristics**

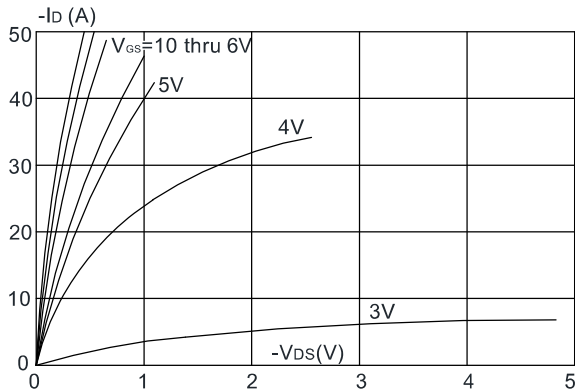

**Figure 2: Typical Transfer Characteristics**

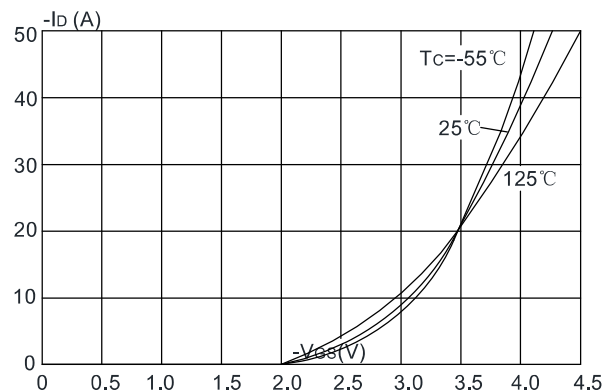

**Figure 3: On-resistance vs. Drain Current**

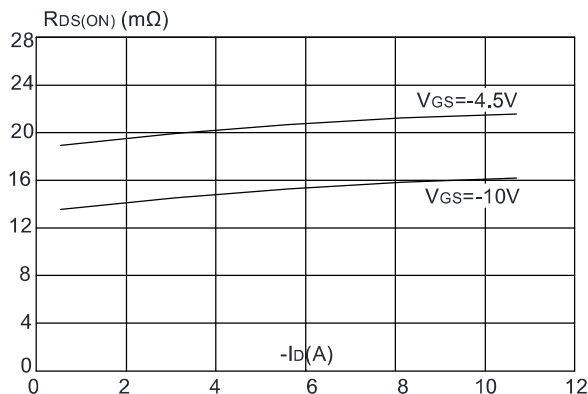

**Figure 4: Body Diode Characteristics**

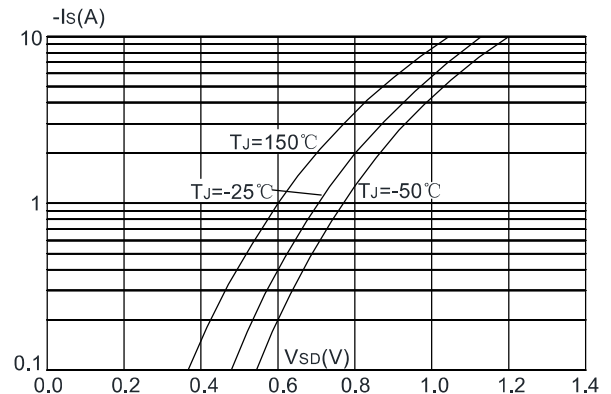

**Figure 5: Gate Charge Characteristics**

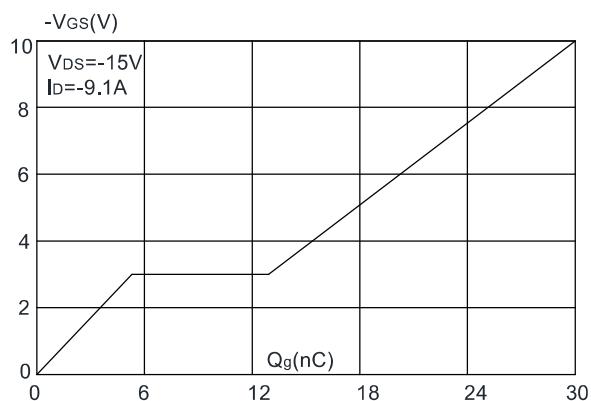

**Figure 6: Capacitance Characteristics**

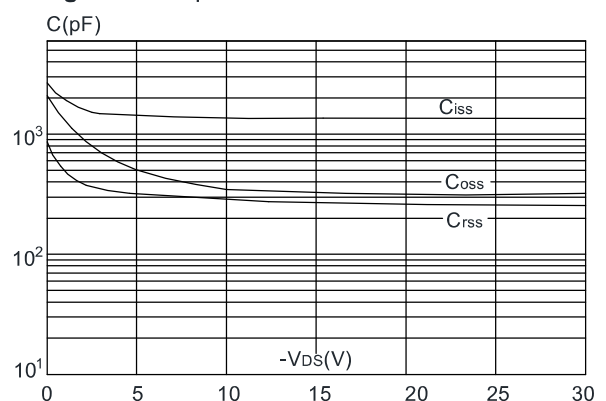

# AP15P03Q

## P-Channel Enhancement Mosfet

**Figure 7:** Normalized Breakdown Voltage vs. Junction Temperature

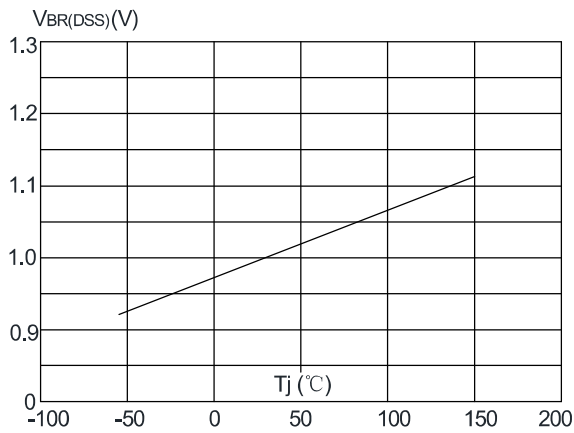

**Figure 8:** Normalized on Resistance vs. Junction Temperature

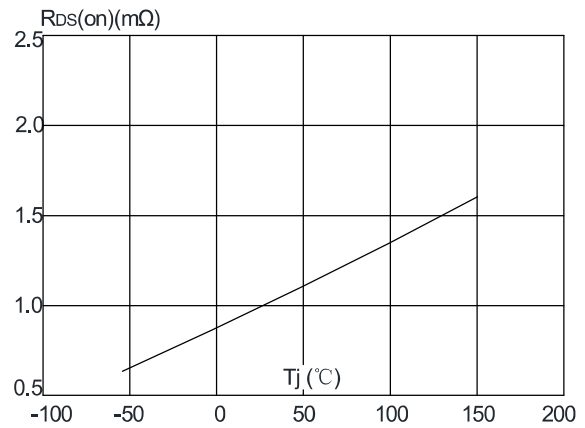

**Figure 9:** Maximum Safe Operating Area

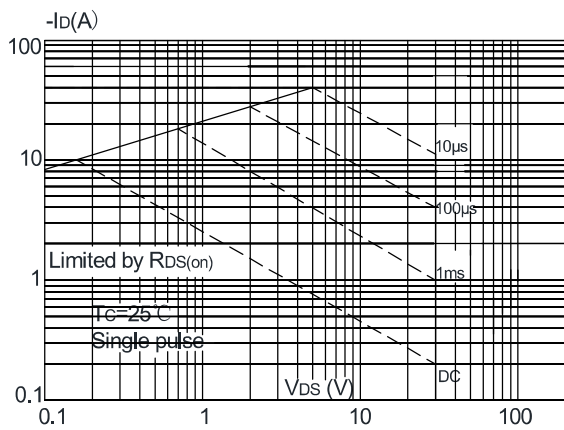

**Figure 10:** Maximum Continuous Drain Current vs. Case Temperature

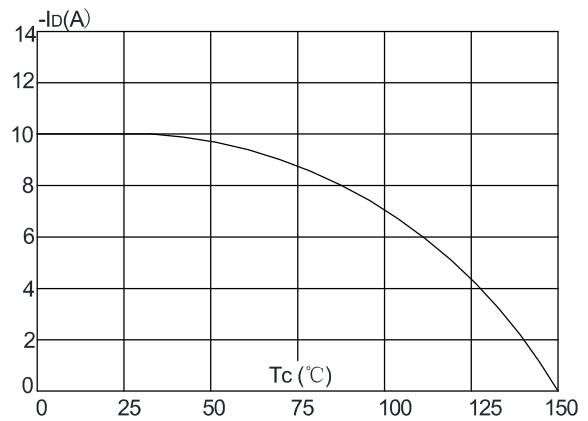

**Figure.11:** Maximum Effective Transient Thermal Impedance, Junction-to-Ambient

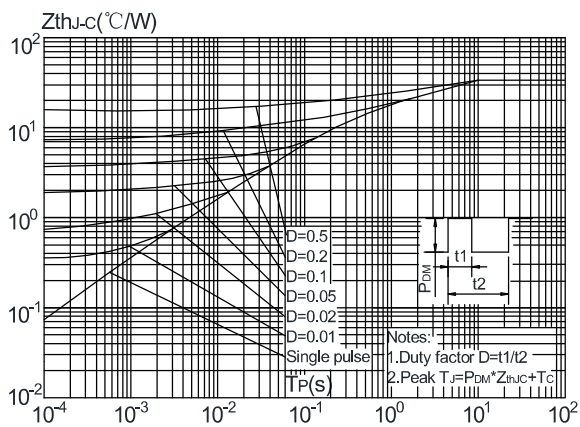

# AP15P03Q

P-Channel Enhancement Mosfet

## PDFN3X3 Package Information

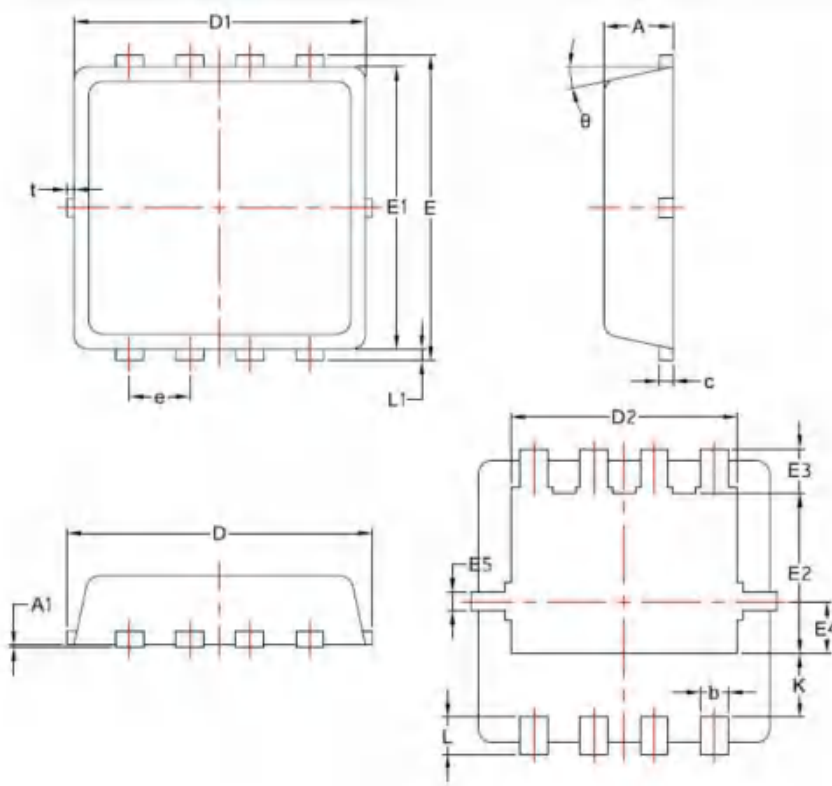

SYMBOL	COMMON		
	MM		
	MIN	NOM	MAX
A	0.70	0.75	0.85
A1	/	/	0.05
b	0.20	0.30	0.40
c	0.10	0.152	0.25
D	3.15	3.30	3.45
D1	3.00	3.15	3.25
D2	2.29	2.45	2.65
E	3.15	3.30	3.45
E1	2.90	3.05	3.20
E2	1.54	1.74	1.94
E3	0.28	0.48	0.65
E4	0.37	0.57	0.77
E5	0.10	0.20	0.30
e	0.60	0.65	0.70
K	0.59	0.69	0.89
L	0.30	0.40	0.50
L1	0.06	0.125	0.20
t	0	0.075	0.13
theta	10°	12°	14°