

AP80N04G

N-Channel Power MOSFET

Features

- 40V,50A
 $R_{DS(ON)}=5.9m\Omega$ (Typ.) @ $V_{GS} = 10V$
 $R_{DS(ON)}=11m\Omega$ (Typ.) @ $V_{GS} = 4.5V$
- High Density Cell Design for Ultra Low $R_{DS(ON)}$
- Fully Characterized Avalanche Voltage and Current
- Good Stability and Uniformity with High E_{AS}
- Excellent Package for Good Heat Dissipation

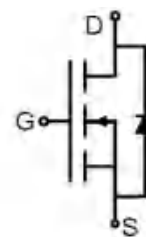

Schematic Diagram

Application

- Load Switch
- Hard Switched and High Frequency Circuits
- Uninterruptible Power Supply

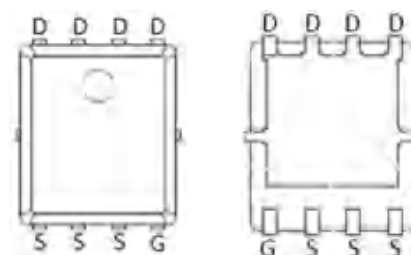

PDFN5X6-8L

Absolute Maximum Ratings ($T_C=25^\circ C$ unless otherwise specified)

Symbol	Parameter	Max.	Units
V_{DSS}	Drain-Source Voltage	40	V
V_{GSS}	Gate-Source Voltage	± 20	V
I_D	Continuous Drain Current	$T_C = 25^\circ C$	50
		$T_C = 100^\circ C$	34
I_{DM}	Pulsed Drain Current ^{note1}	200	A
E_{AS}	Single Pulsed Avalanche Energy ^{note2}	196	mJ
P_D	Power Dissipation	$T_C = 25^\circ C$	42
$R_{\theta JC}$	Thermal Resistance, Junction to Case	3.0	$^\circ C/W$
T_J, T_{STG}	Operating and Storage Temperature Range	-55 to +150	$^\circ C$

AP80N04G
N-Channel Power MOSFET
Electrical Characteristics ($T_C=25^{\circ}\text{C}$ unless otherwise specified)

Symbol	Parameter	Test Condition	Min.	Typ.	Max.	Units
Off Characteristic						
$V_{(BR)DSS}$	Drain-Source Breakdown Voltage	$V_{GS}=0V, I_D=250\mu A$	40	-	-	V
I_{DSS}	Zero Gate Voltage Drain Current	$V_{DS}=40V, V_{GS}=0V,$	-	-	1.0	μA
I_{GSS}	Gate to Body Leakage Current	$V_{DS}=0V, V_{GS}=\pm 20V$	-	-	± 100	nA
On Characteristics						
$V_{GS(th)}$	Gate Threshold Voltage	$V_{DS}=V_{GS}, I_D=250\mu A$	1.0	1.5	2.5	V
$R_{DS(on)}$	Static Drain-Source on-Resistance <small>note3</small>	$V_{GS}=10V, I_D=30A$	-	5.9	7.5	m Ω
		$V_{GS}=4.5V, I_D=20A$	-	11	14	
g_{FS}	Forward Transconductance	$V_{DS}=5V, I_D=15A$	10	27	-	S
Dynamic Characteristics						
C_{iss}	Input Capacitance	$V_{DS}=20V, V_{GS}=0V,$ $f=1.0\text{MHz}$	-	2229	-	pF
C_{oss}	Output Capacitance		-	187	-	pF
C_{rss}	Reverse Transfer Capacitance		-	167	-	pF
Q_g	Total Gate Charge	$V_{DS}=20V, I_D=30A,$ $V_{GS}=10V$	-	48	-	nC
Q_{gs}	Gate-Source Charge		-	6	-	nC
Q_{gd}	Gate-Drain("Miller") Charge		-	13	-	nC
Switching Characteristics						
$t_{d(on)}$	Turn-on Delay Time	$V_{DD}=20V, I_D=30A,$ $R_L=1\Omega, R_{GEN}=3\Omega,$ $V_{GS}=10V$	-	13	-	ns
t_r	Turn-on Rise Time		-	37	-	ns
$t_{d(off)}$	Turn-off Delay Time		-	46	-	ns
t_f	Turn-off Fall Time		-	15	-	ns
Drain-Source Diode Characteristics and Maximum Ratings						
I_S	Maximum Continuous Drain to Source Diode Forward Current		-	-	50	A
I_{SM}	Maximum Pulsed Drain to Source Diode Forward Current		-	-	200	A
V_{SD}	Drain to Source Diode Forward Voltage	$V_{GS}=0V, I_S=30A$	-	-	1.2	V
t_{rr}	Body Diode Reverse Recovery Time	$T_J=25^{\circ}\text{C},$ $I_F=20A, di/dt=100A/\mu s$	-	15	-	ns
Q_{rr}	Body Diode Reverse Recovery Charge		-	6	-	nC

Notes:1. Repetitive Rating: Pulse Width Limited by Maximum Junction Temperature

 2. EAS condition: $T_J=25^{\circ}\text{C}, V_G=10V, R_G=25\Omega, L=0.5\text{mH}$

 3. Pulse Test: Pulse Width $\leq 300\mu s$, Duty Cycle $\leq 0.5\%$

Typical Performance Characteristics

Figure 1: Output Characteristics

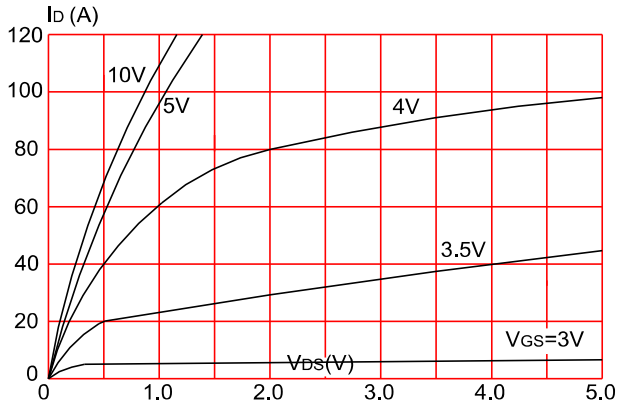

Figure 2: Typical Transfer Characteristics

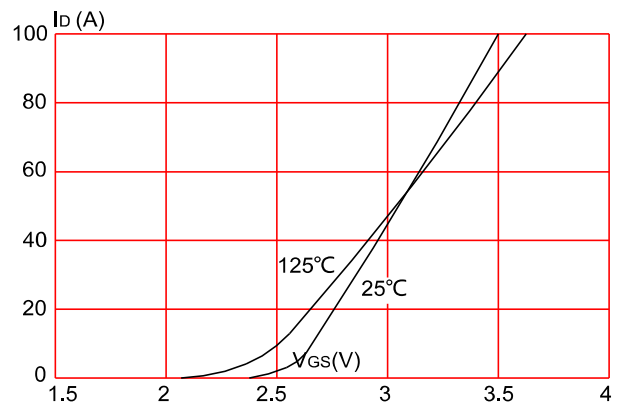

Figure 3: On-resistance vs. Drain Current

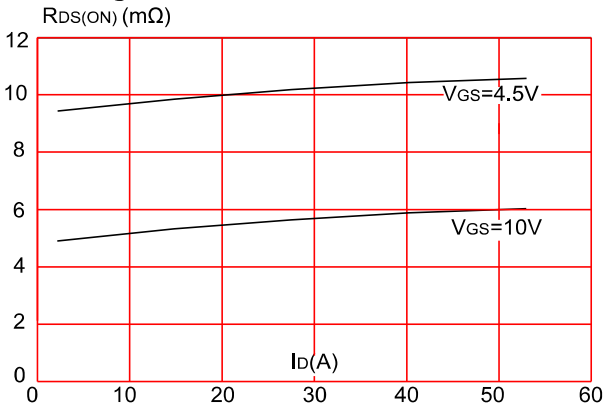

Figure 4: Body Diode Characteristics

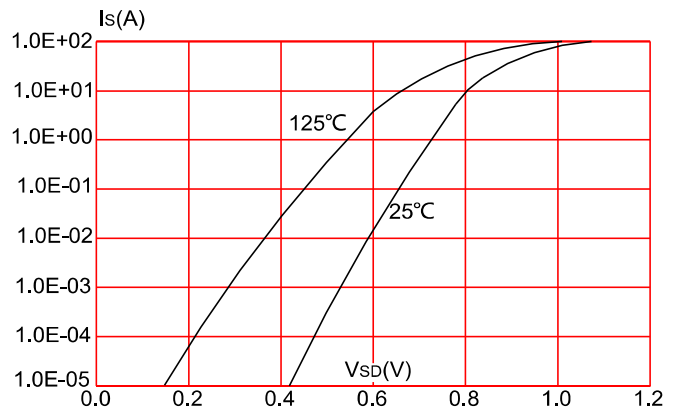

Figure 5: Gate Charge Characteristics

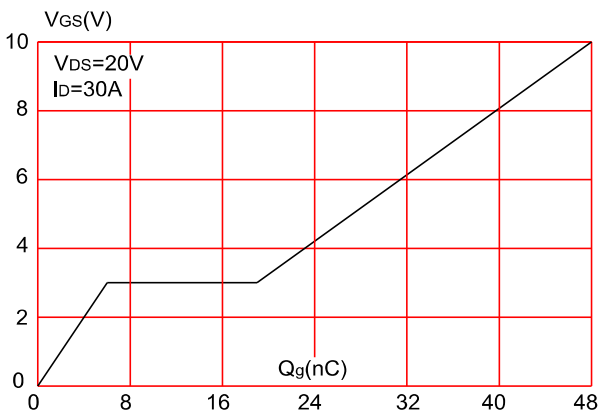
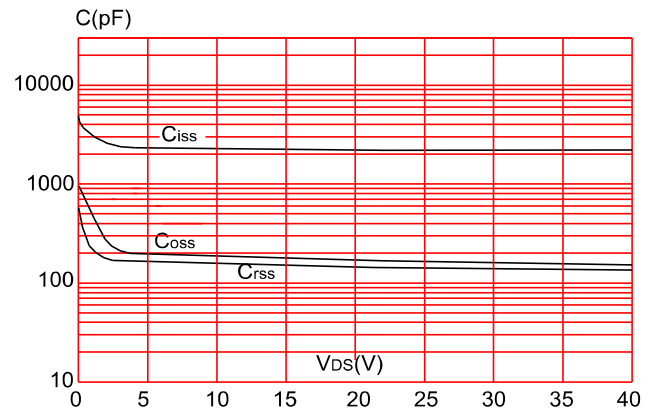

Figure 6: Capacitance Characteristics



AP80N04G
N-Channel Power MOSFET

Figure 7: Normalized Breakdown Voltage vs. Junction Temperature

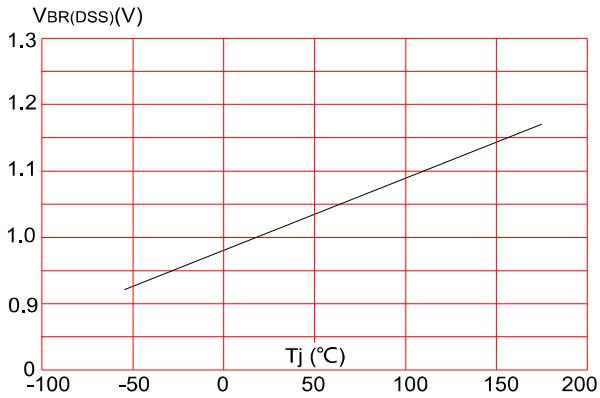

Figure 8: Normalized on Resistance vs. Junction Temperature

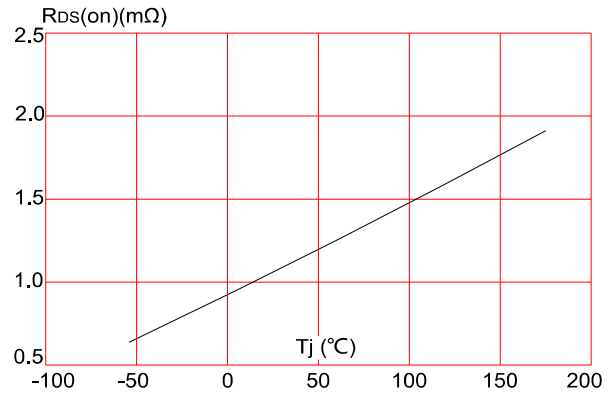

Figure 9: Maximum Safe Operating Area

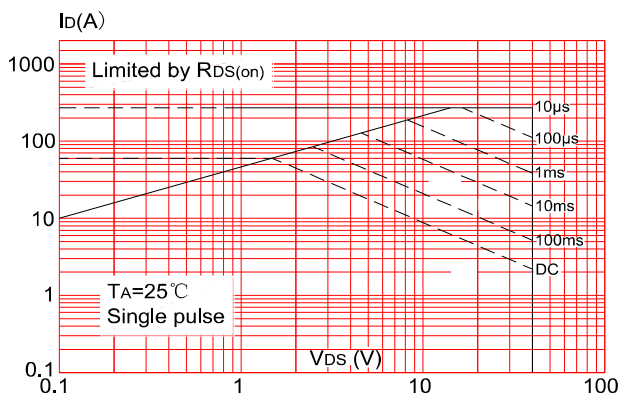

Figure 10: Maximum Continuous Drain Current vs. Case Temperature

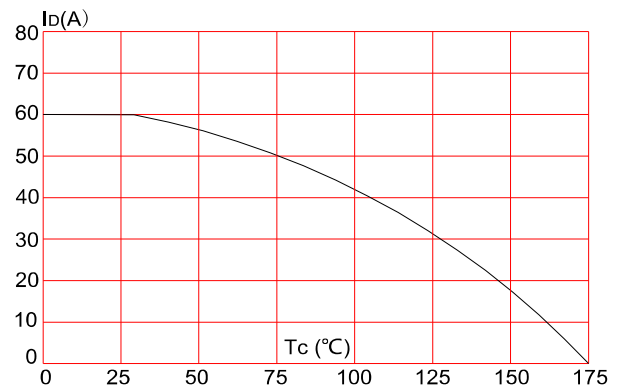
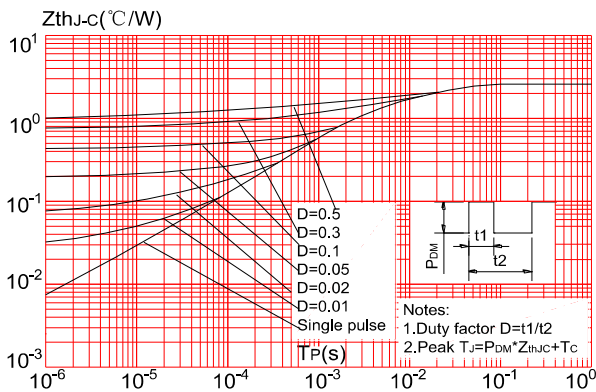

Figure.11: Maximum Effective Transient Thermal Impedance, Junction-to-Case (PDFN3.3*3.3-8L)



AP80N04G
N-Channel Power MOSFET

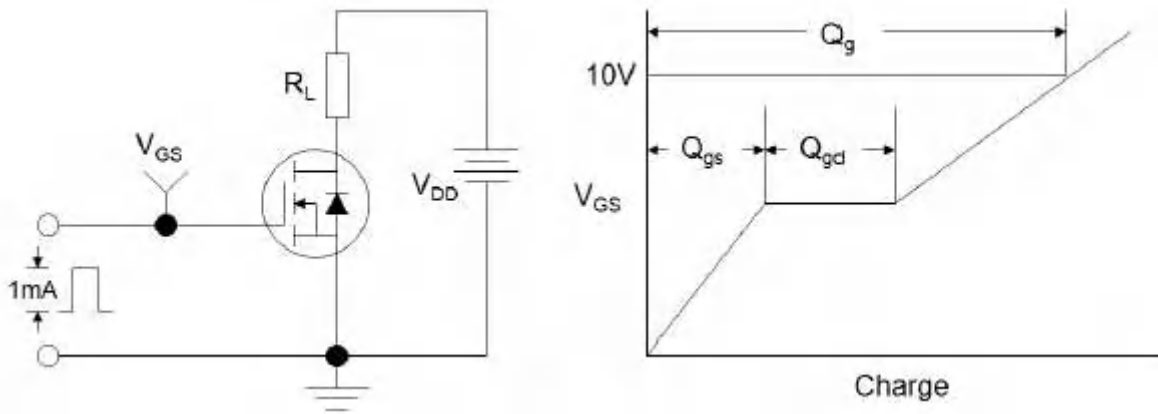

Figure1:Gate Charge Test Circuit & Waveform

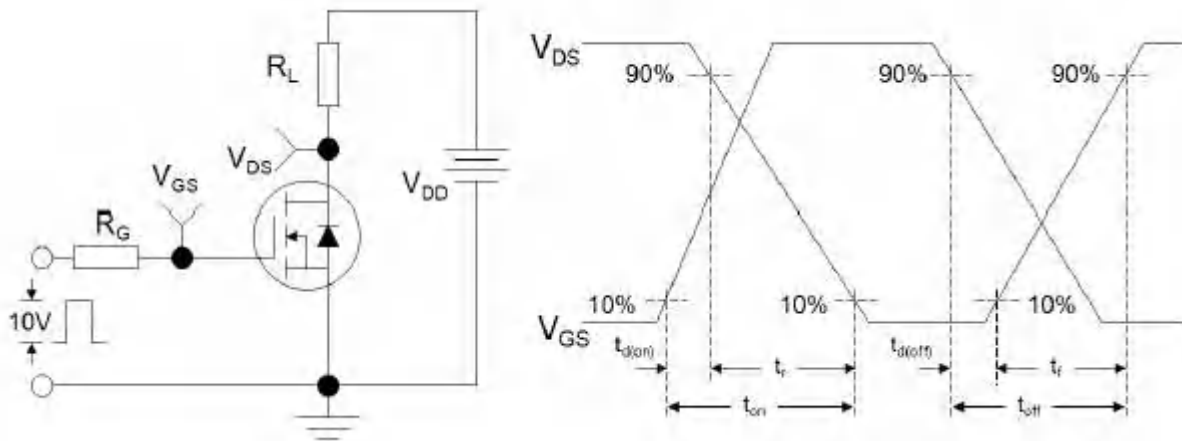

Figure 2: Resistive Switching Test Circuit & Waveforms

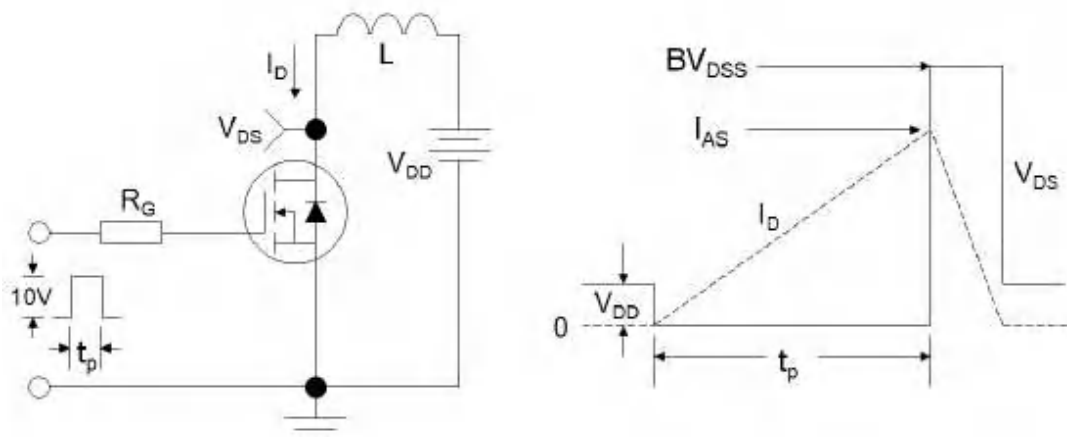

Figure 3:Unclamped Inductive Switching Test Circuit & Waveforms

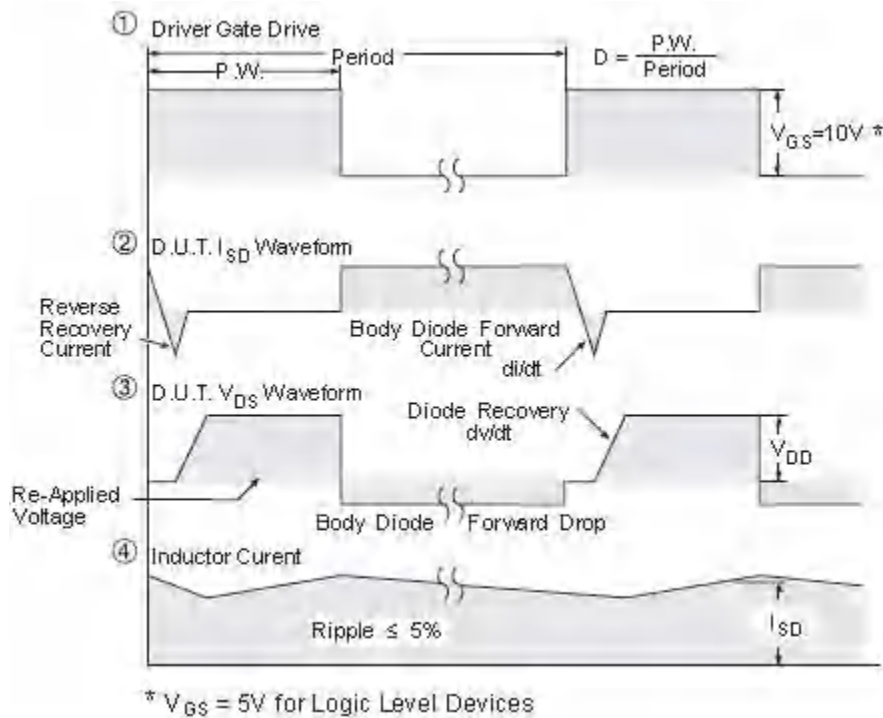
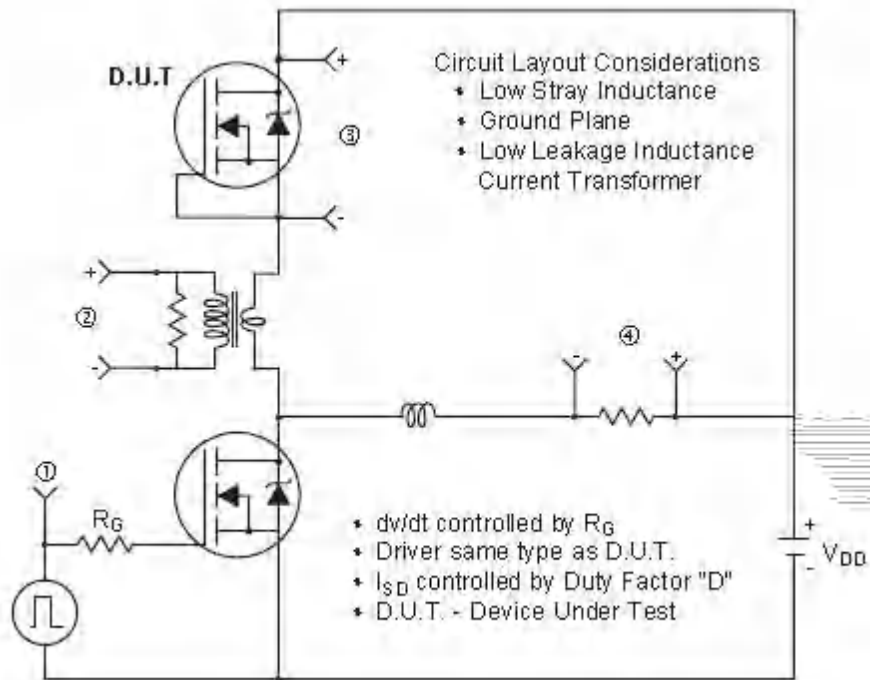
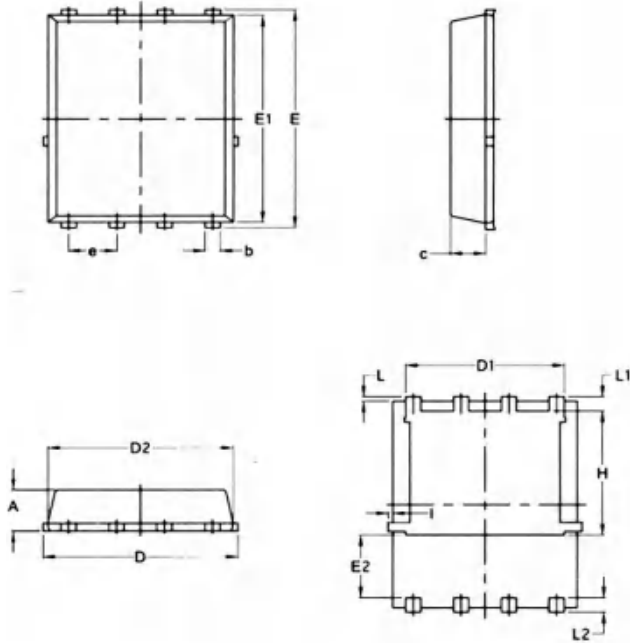

Figure 4: Peak Diode Recovery dv/dt Test Circuit & Waveforms (For N-channel)

AP80N04G

N-Channel Power MOSFET

Package Mechanical Data



PDFN5X6-8L

SYMBOL	COMMON			
	MM		INCH	
	MIN.	MAX.	MIN.	MAX.
A	1.03	1.17	0.0406	0.0461
b	0.34	0.48	0.0134	0.0189
c	0.824	0.970	0.0324	0.0382
D	4.80	5.40	0.1890	0.2126
D1	4.11	4.31	0.1618	0.1697
D2	4.80	5.00	0.1890	0.1969
E	5.95	6.15	0.2343	0.2421
E1	5.65	5.85	0.2224	0.2303
E2	1.60	—	0.0630	—
e	1.27 BSC		0.05 BSC	
L	0.05	0.25	0.0020	0.0098
L1	0.38	0.50	0.0150	0.0197
L2	0.38	0.50	0.0150	0.0197
H	3.30	3.50	0.1299	0.1378
I	—	0.18	—	0.0070