

APG4015G

N-Channel Enhancement Mosfet

Feature

- 40V,150A
 $R_{DS(ON)} < 1.8m\Omega @ V_{GS}=10V$ (TYP:1.6m Ω)
 $R_{DS(ON)} < 3.3m\Omega @ V_{GS}=4.5V$ (TYP:2.0m Ω)
- Split Gate Trench Technology
- Lead free product is acquired
- Excellent $R_{DS(ON)}$ and Low Gate Charge

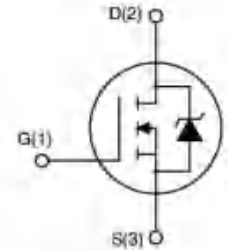

Application

- PWM applications
- Load Switch
- Power management

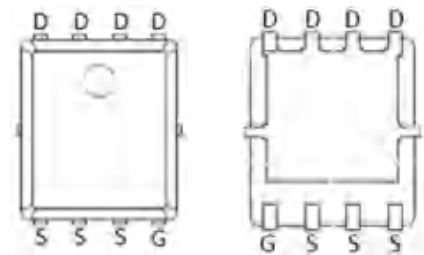

PDFN5X6-8L

Package Marking and Ordering Information

Device Marking	Device	Device Package	Reel Size	Tape width	Quantity (PCS)
G4015	APG4015G	PDFN5*6-8L	13 inch	-	5000

ABSOLUTE MAXIMUM RATINGS ($T_a=25^{\circ}C$ unless otherwise noted)

Parameter	Symbol	Value	Unit
Drain-Source Voltage	V_{DS}	40	V
Gate-Source Voltage	V_{GS}	± 20	V
Continuous Drain Current ($T_a=25^{\circ}C$)	I_D	150	A
Continuous Drain Current ($T_a=100^{\circ}C$)	I_D	100	A
Pulsed Drain Current ⁽¹⁾	I_{DM}	400	A
Singel Pulsed Avalanche Energy ⁽²⁾	E_{AS}	320	mJ
Power Dissipation	P_D	89	W
Thermal Resistance from Junction to Case	$R_{\theta JC}$	1.4	$^{\circ}C/W$
Junction Temperature	T_J	150	$^{\circ}C$
Storage Temperature	T_{STG}	-55~ +150	$^{\circ}C$

MOSFET ELECTRICAL CHARACTERISTICS($T_a=25^{\circ}\text{C}$ unless otherwise noted)

Parameter	Symbol	Test Condition	Min	Type	Max	Unit
Static Characteristics						
Drain-source breakdown voltage	$V_{(BR)DSS}$	$V_{GS} = 0V, I_D = 250\mu A$	40	-	-	V
Zero gate voltage drain current	I_{DSS}	$V_{DS} = 40V, V_{GS} = 0V$	-	-	1	μA
Gate-body leakage current	I_{GSS}	$V_{GS} = \pm 20V, V_{DS} = 0V$	-	-	± 100	nA
Gate threshold voltage ⁽³⁾	$V_{GS(th)}$	$V_{DS} = V_{GS}, I_D = 250\mu A$	1.0	1.7	2.5	V
Drain-source on-resistance ⁽³⁾	$R_{DS(on)}$	$V_{GS} = 10V, I_D = 75A$	-	1.6	1.8	m Ω
		$V_{GS} = 4.5V, I_D = 30A$	-	2	3.3	
Forward Threshold Voltage	g_{fs}	$V_{DS} = 5V, I_D = 75A$	60	-	-	S
Gate Resistance	R_g	$V_{DS} = V_{GS} = 0V, f = 1MHz$	-	1.94	-	Ω
Dynamic characteristics						
Input Capacitance	C_{iss}	$V_{DS} = 20V, V_{GS} = 0V, f = 1MHz$	-	3000	-	pF
Output Capacitance	C_{oss}		-	895	-	
Reverse Transfer Capacitance	C_{rss}		-	37	-	
Switching characteristics						
Turn-on delay time	$t_{d(on)}$	$V_{DD} = 20V, I_D = 75A,$ $V_{GS} = 10V, R_G = 3\Omega$	-	13	-	ns
Turn-on rise time	t_r		-	3	-	
Turn-off delay time	$t_{d(off)}$		-	52	-	
Turn-off fall time	t_f		-	24	-	
Total Gate Charge	Q_g	$V_{DS} = 20V, I_D = 75A,$ $V_{GS} = 10V$	-	40	-	nC
Gate-Source Charge	Q_{gs}		-	8	-	
Gate-Drain Charge	Q_{gd}		-	7	-	
Reverse Recovery Chrage	Q_{rr}	$I_F = 50A, di/dt = 100A/us$		31		nC
Reverse Recovery Time	T_{rr}	$I_F = 50A, di/dt = 100A/us$		35		ns
Source-Drain Diode characteristics						
Diode Forward voltage ⁽³⁾	V_{DS}	$V_{GS} = 0V, I_S = 75A$	-	-	1.2	V
Diode Forward current ⁽⁴⁾	I_S		-	-	150	A

Notes:

1. Repetitive Rating: pulse width limited by maximum junction temperature
2. EAS Condition: $T_J = 25^{\circ}\text{C}, V_{DD} = 20V, R_G = 25\Omega, L = 0.5mH$
3. Pulse Test: pulse width $\leq 300\mu s$, duty cycle $\leq 2\%$
4. Surface Mounted on FR4 Board, $t \leq 10\text{ sec}$

Test Circuit & Waveform

Gate Charge Test Circuit & Waveform

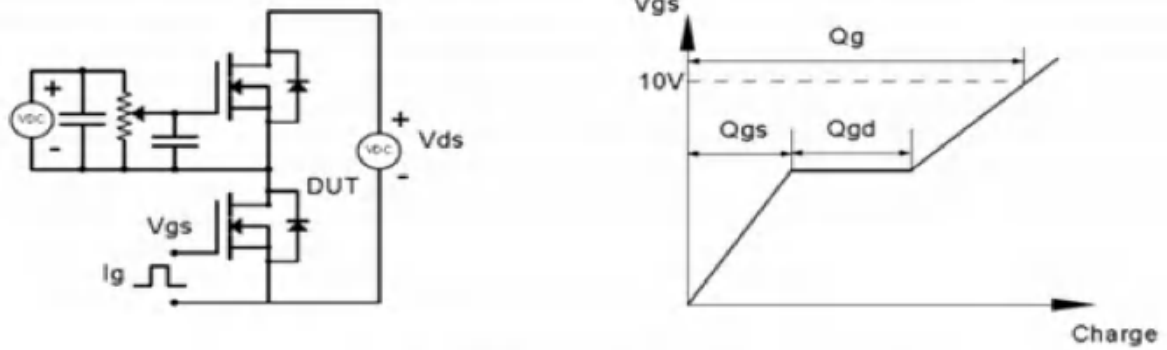

Resistive Switching Test Circuit & Waveforms

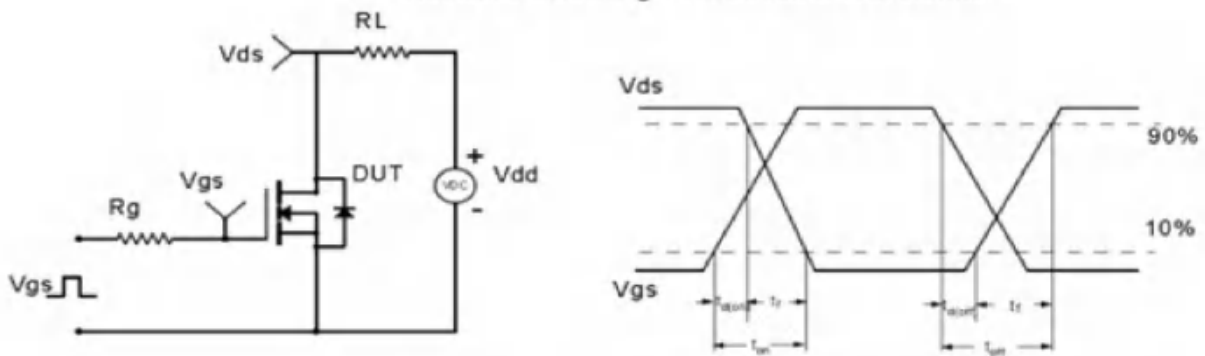

Unclamped Inductive Switching (UIS) Test Circuit & Waveforms

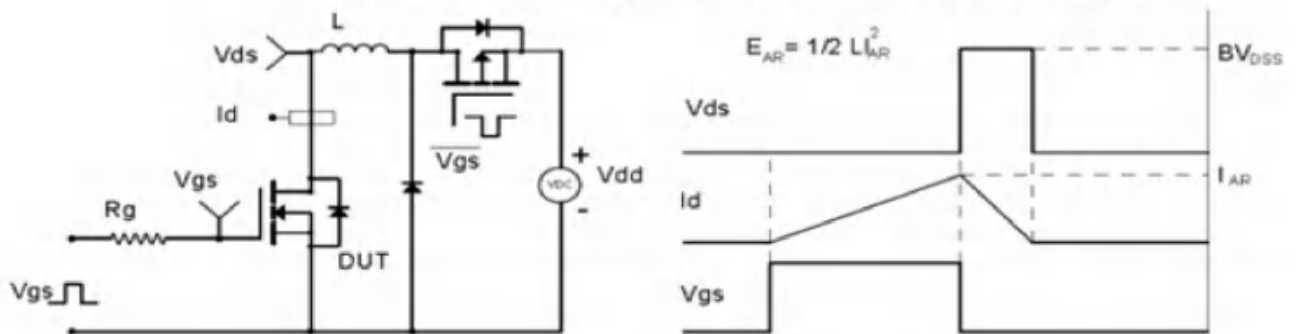

Diode Recovery Test Circuit & Waveforms

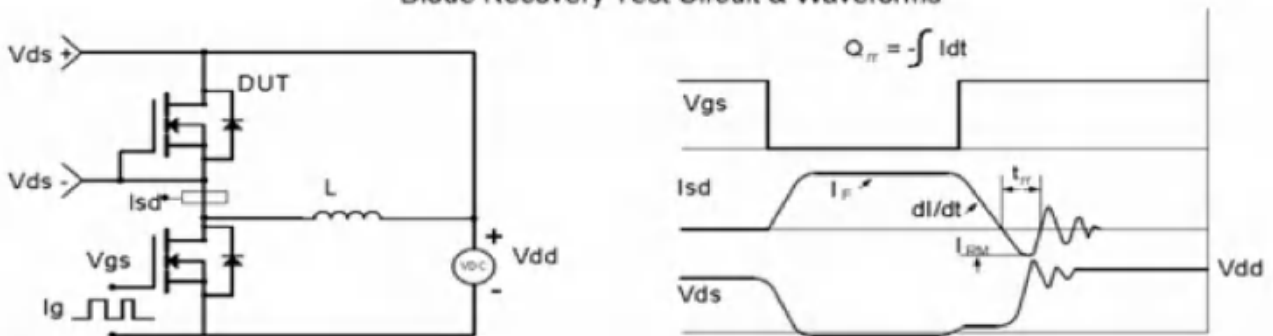

Typical Performance Characteristics

Fig.1 Power Dissipation Derating Curve

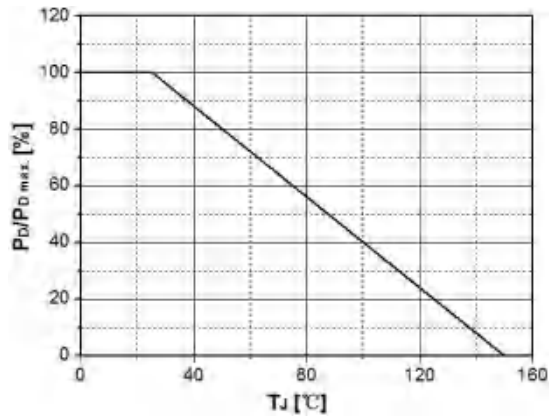

Fig.2 Avalanche Energy Derating Curve vs. Junction Temperature

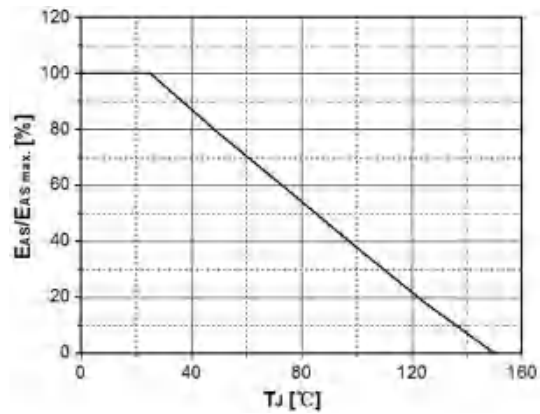

Fig.3 Typical Output Characteristics

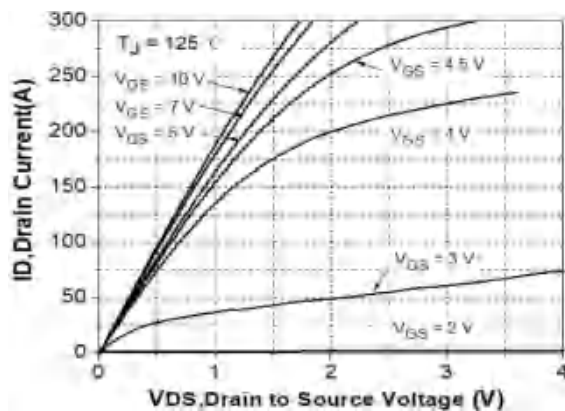

Fig. 4 Transconductance vs. Drain Current

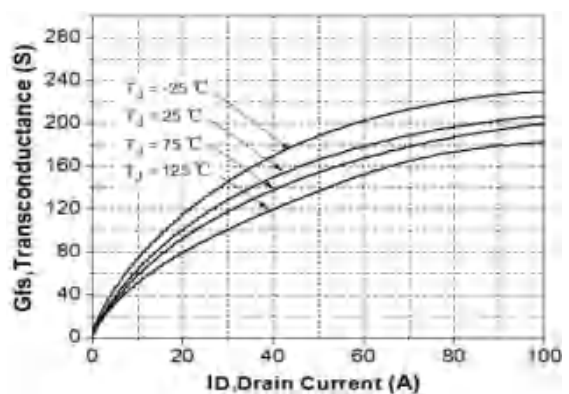

Fig.5 Typical Transfer Characteristics

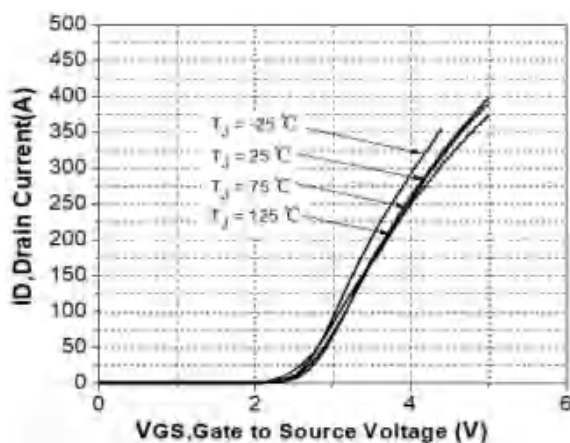

Fig. 6 State Resistance vs. Drain Current @-25°C

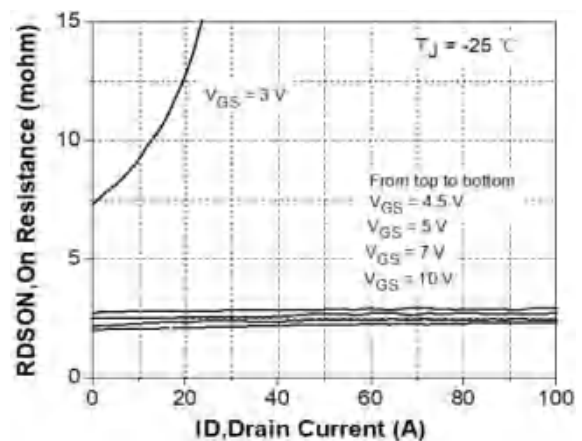

Fig.7 State Resistance vs. Drain Current @25°C

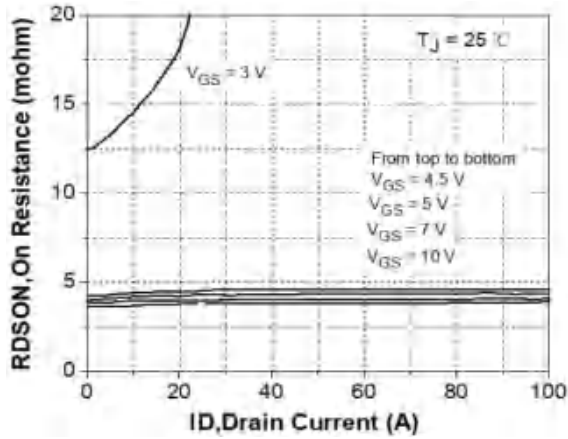

Fig. 8 State Resistance vs. Drain Current @125°C

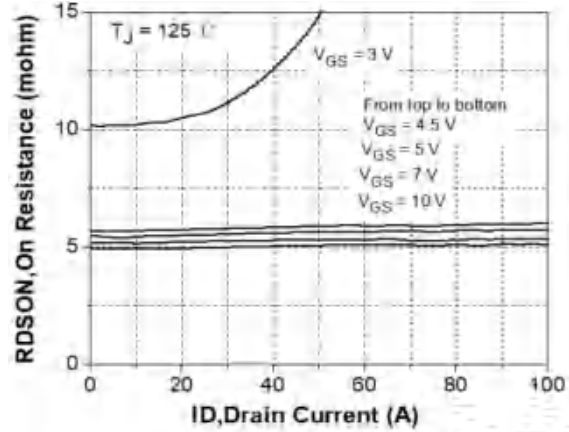

Fig.9 Typical Capacitance vs. Drain Source Voltage

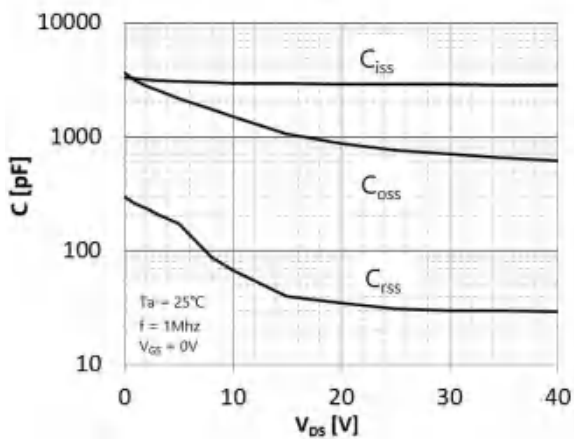

Fig.10 Dynamic Input Characteristics

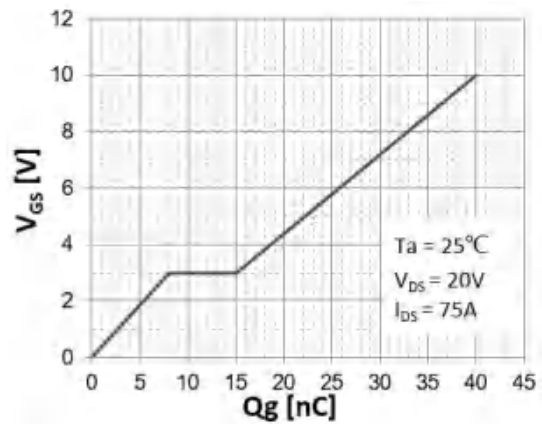

Fig.11 Breakdown Voltage vs. Junction Temperature

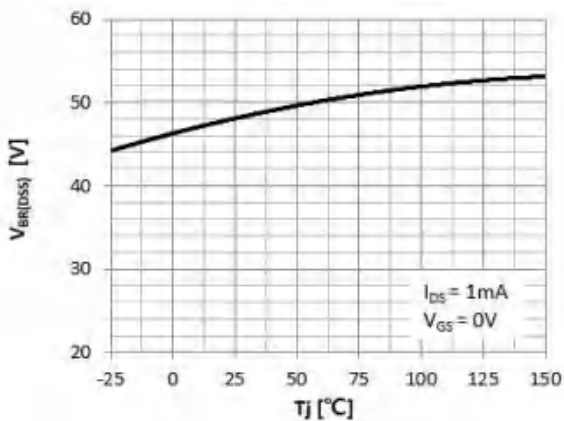
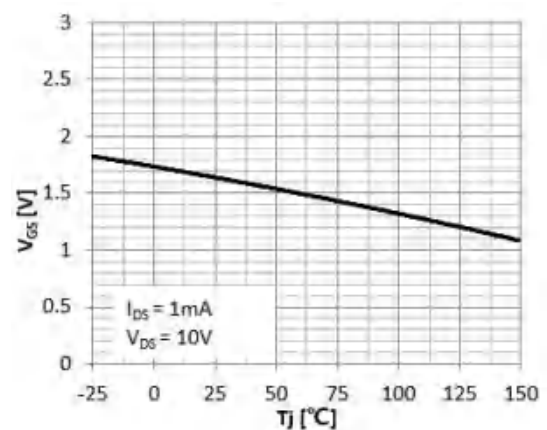
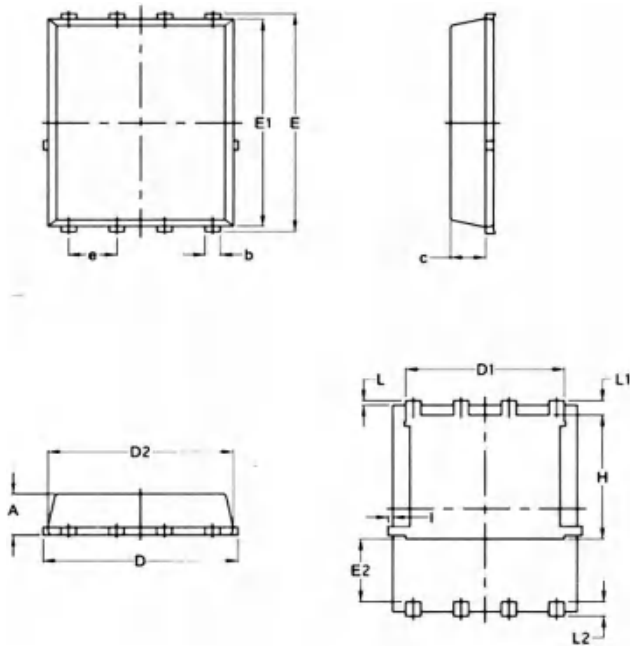

Fig. 12 Gate Threshold Voltage vs. Junction Temperature



PDFN5*6-8L Package Information



PDFN5X6-8L

SYMBOL	COMMON			
	MM		INCH	
	MIN.	MAX.	MIN.	MAX.
A	1.03	1.17	0.0406	0.0461
b	0.34	0.48	0.0134	0.0189
c	0.824	0.970	0.0324	0.0382
D	4.80	5.40	0.1890	0.2126
D1	4.11	4.31	0.1618	0.1697
D2	4.80	5.00	0.1890	0.1969
E	5.95	6.15	0.2343	0.2421
E1	5.65	5.85	0.2224	0.2303
E2	1.60	—	0.0630	—
e	1.27 BSC		0.05 BSC	
L	0.05	0.25	0.0020	0.0098
L1	0.38	0.50	0.0150	0.0197
L2	0.38	0.50	0.0150	0.0197
H	3.30	3.50	0.1299	0.1378
I	—	0.18	—	0.0070